

Datasheet

MOBILETT Elara Max

Stands out from the crowd
in mobile X-ray imaging

siemens-healthineers.com/mobilett-elara-max



Technical specifications

Discover how you can stand out from the crowd in mobile X-ray imaging with MOBILETT Elara Max

Unique MAXreach arm
for outstanding positioning flexibility

Status indicator lights
for a visual safety signal

High-contrast monitor
for improved visibility

Intelligent charging concept
for ready-to-go detectors

Hygienic system design
with integrated cables,
smooth and closed surfaces

**Robust, compact and
lightweight design**
for exceptional maneuverability

Always ready
even when all batteries are empty

Size
Height: 157 cm
Width: 59.8 cm
Depth: 127.8 cm





MAX mini¹
is ideal for incubators
and extremities

MAX wi-D¹
is light, thin, fast

MAXswap
for advanced detector sharing



DiamondView MAX
for enhanced contrast
and detail

syngo FLC
for an easy-to-learn,
common user interface

**Virtual workstation¹ and
wireless connectivity**
for unrestricted data access



Table of contents

System specifications		System options	
Mobile X-ray unit	5	Remote control	14
syngo FLC hardware	5	WLAN connectivity	14
Generator	6	Miscellaneous	14
X-ray tube	7		
Dose Area Product (DAP) measurement chamber	7	Working environment	
MAX wi-D	8	Operating data	15
MAX mini	9	Environmental conditions	16
Patient data administration	10	Dimensions and weight	16
Virtual Workstation	10		
Clinical workflow		Room planning	
Cyber Security	11	Dimensioned drawings	17
Examination preparation	11		
Image acquisition/display/processing	12		
Data transfer and documentation	13		

System specifications

Mobile X-ray unit

General-purpose digital mobile X-ray unit for radiography of the recumbent and seated patient

High-frequency generator (50 kHz)

Forward/Reverse motor drive for relocating the unit, controlled at main handle

Max. incline of 7 degrees, high speed adjustable from 1.2 to 1.5 m/s

Ever ready: Even when all batteries are depleted, the unit can be moved manually and examinations can be performed with mains power (with slightly reduced maximum power)

Reduced speed feature (creep mode) for fine tuning unit positioning from the arm

Counterbalanced arm can be rotated by ± 90 degrees and allows easy adjustment for all the different projections

Flexible X-ray tube

Exposure release via hand switch or remote control¹⁾

LED collimator light: can be switched on via hand switch, control panel or remote control¹⁾

Automatic cable winder with 4 m (157.5") power cable for connection to any grounded outlet

Available with numeric keypad / PIN code (alternative: standard key switch¹⁾)

System can be locked without requiring a shutdown

syngo FLC hardware

The X-ray system incl. digital image processing is controlled from the central, integrated image and control station

High-end PC imaging system based on Windows 10 with syngo-like user interface

17" color high-contrast display for touch screen operation

Memory capacity approx. 10,000 images

Connection to hospital network via LAN (up to 1 Gbit/s) and/or WLAN¹⁾ (up to 65 Mbit/s)

¹⁾ Option

System specifications

Generator

Power output	Max. 133 kV at 225 mA Max. 450 mA at 54 kV Max. 35 kW at 96 kV, 365 mA, 10 ms Max. 30 kW at 99 kV, 300 mA, 100 ms (acc. to IEC 60601-2-7) Min. 0.32 mAs
kVp range	40 kV to 133 kV in 47 steps
mAs range	0.32 mAs to 360 mAs in 53 steps
kV accuracy	$< \pm 3$ kV (40 kV to 60 kV) $< \pm 5\%$ (60 kV to 133 kV)
mAs accuracy	$< \pm 5\%$ (2 mAs to 360 mAs) $< \pm 0.1$ mAs (0.32 mAs to 2 mAs)
Shortest exposure time	1 ms
Max. exposure time	3.2 s (digital mode)
Exposure release	Detachable remote control with 5 m coiled cord
Enclosure protection rating	IPX0 (not protected)
Protection against electric shock	Class I acc. to IEC 60601-1

¹⁾ Option

System specifications

X-ray tube

Tube housing (single tank with rotating-anode tube)

X-ray tube	Siemens Healthineers P135/30 R
Stabilization	Microprocessor-based adjustment and regulation during exposure
Focal spot nominal value (IEC 336)	0.8
Anode angle	15°
Anode speed	Up to 9,000 r.p.m., 150 Hz
Heat storage capacity of tube housing	800,000 J = 1,100,000 HU
Heat storage capacity of anode	90,000 J = 122,000 HU
Collimator	Manually adjustable multileaf collimator, rotatable ± 90°
Collimator light and light field intensity	LED min. 180 lux at 1 m SID
Tube housing assembly	Maximum temperature 60 °C, maximum 2,000 mAs/h, nominal continuous rating 75 W until housing temperature reaches 60 °C

Dose Area Product (DAP) measurement chamber

Integrated dose area product measurement system	
Automatic transfer of the dose value measured to the imaging system	
Part of the DICOM header when image information is transferred	
Typical filtration	< 0.4 mm Al equivalent
DAP resolution	0.01 µGym ²
Maximum measurable DAP	1 x 10 ⁵ µGym ²

¹⁾ Option

System specifications

MAX wi-D¹⁾

Detector technology	Cesium iodide scintillator coupled to TFT matrix with amorphous silicon technology
Dimensions (active area)	34.8 cm x 42.4 cm (13.7" x 16.7")
Active detector matrix	2350 x 2866
Dimensions with detector housing	44 cm x 46.1 cm x 1.9 cm (17.3" x 18.1" x 0.75")
Pixel size	148 µm
Semiconductor material	Amorphous silicon (a-Si)
Scintillator	Cesium iodide (CsI)
Digitization depth	16 bits
DQE in %; 2 µGy (RQA5)	70 % at 0.05 lp/mm 51 % at 1 lp/mm, (IEC 62220) 42 % at 2 lp/mm, (IEC 62220) 29 % at 3 lp/mm, (IEC 62220) 19 % at Nyquist
MTF in % (RQA5)	63 % at 1 lp/mm, (IEC 62220) 35 % at 2 lp/mm, (IEC 62220) 19 % at 3 lp/mm, (IEC 62220) 15 % at Nyquist
Data transmission	WLAN ²⁾ < 2 s preview; < 5 s full image
Thickness	19 mm (0.75")
Weight	3.3 kg (7.3 lbs)
Max. load capacity	300 kg (661 lbs) with patient recumbent 100 kg (221 lbs) with patient standing
Battery	Lithium-ion, rechargeable, exchangeable
Charging time	90 minutes for 80 % battery capacity
Battery operation time	Up to 1050 images Up to 6.5 h during regular utilization Up to 11.7 h in standby mode
Clip-on grid ¹⁾	Grid, Pb 5/85, f ₀ = 115 cm; Pb with aluminum interspacing
Charging location	Onboard detector holder, or external battery charger ¹⁾
WLAN Standard	IEEE 802.11n, 2 x 2 mimo
If there is a WLAN or other wireless equipment in your working environment, please consult your Siemens Healthineers representative for optimal set-up of the wireless connection	
IEC Regulations	Electromagnetic compatibility: compliance with IEC 60601-1-2 ed. 4 This detector does not affect pacemakers that comply with DIN EN 45502-2-1, Section 27
MAXswap	Detectors are shareable between multiple MAX systems

¹⁾ Option

²⁾ The preview/full image transmission time depends on the quality of the WiFi link and the selected processing parameters

System specifications

MAX mini ¹⁾	
Detector technology	Cesium iodide scintillator coupled to TFT matrix with amorphous silicon technology
Dimensions (active area)	22.5 cm x 28.4 cm (8.9" x 11.2")
Active detector matrix	1520 x 1920
Dimensions with detector housing	26.9 cm x 32.9 cm x 1.6 cm (10.6" x 13" x 0.63")
Pixel size	148 µm
Semiconductor material	Amorphous silicon (a-Si)
Scintillator	Cesium iodide (CsI)
Digitization depth	16 bits
DQE in %; 2 µGy (RQA5)	70 % at 0.05 lp/mm 51 % at 1 lp/mm, (IEC 62220) 42 % at 2 lp/mm, (IEC 62220) 29 % at 3 lp/mm, (IEC 62220) 19 % at Nyquist
MTF in % (RQA5)	63 % at 1 lp/mm, (IEC 62220) 35 % at 2 lp/mm, (IEC 62220) 19 % at 3 lp/mm, (IEC 62220) 15 % at Nyquist
Data transmission	WLAN ²⁾ < 1.5 s preview; < 3.5 s full image
Thickness	16 mm (0.63")
Weight	1.6 kg (3.5 lbs)
Max. load capacity	300 kg (661 lbs) with patient recumbent 100 kg (221 lbs) with patient standing
Battery	Lithium-ion, rechargeable, exchangeable
Charging time	3 h in battery charger for 100% battery capacity
Battery operation time	Up to 1050 images Up to 6.5 h during regular utilization Up to 11.7 h in standby mode
Charging location	External battery charger ¹⁾
WLAN Standard	IEEE 802.11n, 2 x 2 mimo
If there is a WLAN or other wireless equipment in your working environment, please consult your Siemens Healthineers representative for optimal set-up of the wireless connection	
IEC Regulations	Electromagnetic compatibility: compliance with IEC 60601-1-2 ed. 4 This detector does not affect pacemakers that comply with DIN EN 45502-2-1, Section 27
MAXswap	Detectors are shareable between multiple MAX systems

¹⁾ Option

²⁾ The preview/full image transmission time depends on the quality of the WiFi link and the selected processing parameters

System specifications

Patient data administration

Patient registration	Retrieval of patient list and examination data from the hospital/radiology information system (HIS/RIS) Emergency patient registration Patient, study and image data administration Configurable patient registration page Advanced user management (see Cyber Security)
----------------------	--

Virtual Workstation¹⁾

Virtualized Windows 10 environment

Allows installation of hospital specific applications for viewing and information, e.g. RIS client, PACS viewer, etc.

Switch between system screen and virtual workstation with a single interaction

¹⁾ Option

Clinical workflow

Cyber Security

Secure development cycle	Threat and Risk Analysis, Secure Architecture & Design, Secure Configuration and Hardening, Secure Coding & Testing with Vulnerability Scanning, Penetration Testing
Whitelisting	Malware protection based on Microsoft Device Guard
Hard Disk Encryption	Encryption of patient data on internal hard disk with Bitlocker (on customer request)
IPv6	It is possible to configure IP addresses in IPv4 or IPv6 format
High frequency hotfix delivery	Providing hotfixes for 3rd party components (e.g. Microsoft) every 90 days
Advanced security package ¹⁾	Advanced user management: Active directory integration, individual password management and user authorization Audit trail management: Detailed tracking of user and system actions and centralized automated logging DICOM encryption

Examination preparation

Workflow	<p>Prior to acquisition, the patient data is entered via the patient management system (HIS/RIS) or at the control console</p> <p>The exposure parameters are selected via the organ programs</p> <p>Then the patient and X-ray unit are positioned and the exposure is released</p> <p>The exposure released at the central system control is read by the detector within a few seconds</p> <p>The image is shown on the control display for orientation and is available at the imaging system output for sending in DICOM format, e.g. to reporting workstations, imaging networks, laser cameras, etc.</p> <p>Collection of deleted images, studies and patient data including evaluation options</p> <p>Key-protected by numeric keypad / PIN code (alternative: standard key switch¹⁾)</p>
----------	---

¹⁾ Option

Clinical workflow

Image acquisition/display/processing

Acquisition and preprocessing	Selection of generator parameters, setting of parameters for image preprocessing (amplification, harmonization, edge enhancement and LUT) or DiamondView MAX Display of image markers
Image display	Fit to window view of full image
Image processing functions	Rotation, vertical and horizontal reversal, zoom, windowing for contrast/brightness, black/white image inversion
DiamondView MAX	DiamondView MAX is a specially developed image processing method (multispatial filtering) that optimizes the image display specifically for different organ regions Structures of different frequency ranges are weighted differently, allowing precise detail visualization even with large differences in absorption, such as in bone and soft tissue
Graphic functions	Quantification with angle/distance measurement
Text functions	Marking, annotation, image comments, R/L markers
Gridless Acquisition	Gridless acquisition (esp. Thorax) using DiamondView MAX functionalities for superior contrast and easier handling
Image impression	Simplified setting of image impression according to the policy of the customer institution
Tube/line enhancement	Amplified display of tubes and lines in the image for position control

¹⁾ Option

Clinical workflow

Data transfer and documentation

DICOM network interfaces

DICOM Send/StC	Transmission of images to a DICOM network for viewing and archiving Confirmation from the image archive (StC = Storage Commitment)
DICOM Print	Printing of images to a DICOM laser camera via virtual film sheet
DICOM Query/Retrieve	Retrieval of images to a picture archival system (PACS)
DICOM encryption ¹⁾	Sending encrypted patient data to DICOM nodes which can receive encrypted images
DICOM Worklist/MPPS	Get Worklist function for importing patient data from a data management system (RIS/HIS). XRF, CR and DX worklist entries supported, configurable Modality Performed Procedure Step (MPPS) function for sending examination statistics and dose information to a data management system
DICOM Dose Structured Report	Sending of dose values for each study to an archiving system

Documentation

Image data management	Transmission of images to network Automatic and selective printing with virtual film sheet Up to 3 network nodes at the same time and one laser camera configurable Export of image data to CD/DVD recorder in DICOM or TIFF format Export to USB device in DICOM or TIFF format
Recycle bin	This feature can be enabled or disabled Stores rejected and deleted images that are not archived and not printed in a separate folder
Clinical Assurance Program (CAP)	Provides statistics of rejected images
Exposure index (EXI) monitoring	Provides minimum and maximum EXI value for export IEC standard 62494-1 Ed.1
Printer connection ¹⁾	For paper printing to a Level 2 PostScript printer
Smart Remote Service (SRS) ²⁾	Connects MOBILETT Elara Max to the service experts in our Customer Care Center Allows hardware and software remote diagnosis Allows remote system configurations, e.g. adding a DICOM node etc. Enables delivery of remote software updates Remote Assist (based on TeamViewer®) enables screen sharing between you and our Application Specialists for real-time support

¹⁾ Option

²⁾ Depending on service level agreement

System options

Remote control ¹⁾

Infrared remote control unit for exposure release for optimal radiation protection

Operating range	10 m (33 ft), 180°
Battery	For 30,000 exposures
Remote finder function	Locates the remote control when it is not in park position

WLAN connectivity ¹⁾

Industrial-strength WLAN module for increased reach and improved connectivity

Supported WLAN standards	802.11 a/b/e/g/h/i/n
Supported frequency bands	2.4 / 5 GHz
Security / Authentication	802.11 i, 802.1x, WPA/WPA2 WPA2 Enterprise supplicants EAP-TLS, EAP-TTLS (MSCHAPv2), EAP-PEAP (MSCHAPv2) Supports certificates and private key upload / storage (multiple)
Data encryption	TKIP, AES

Miscellaneous

Pediatric filters ¹⁾	Transparent filters for lowering the patient entry dose, available in strengths of 1.0 mm Al + 0.1 mm Cu and 1.0 mm Al + 0.2 mm Cu
Wipe dispenser accessory ¹⁾	Safely stores pens, markers, a cup and a standard, round 5 inch container e.g. for disinfectant wipes
Key switch ¹⁾	System access control using a conventional hardware key
Giraffe ¹⁾	Giraffe design for the system, creating a friendly atmosphere not only in pediatric environments.

¹⁾ Option

Working environment

Operating data		
Power supply	Grounded safety power socket (L/N/Gnd)	
Overcurrent release	An on-site 15 A/characteristic C overcurrent release (circuit breaker) is recommended by DIN VDE 0100-710 for power supply voltages of 230 V/240 V Country-specific requirements apply for the fuse values to be used for other power supply voltages	
Line voltage	100 V to 240 V~ 50/60 Hz 10 A to 6 A 1.2 kW	
Standard battery pack (65 Ah)	Battery	Sealed lead acid batteries (65 Ah), rechargeable
	Charging time	5 h (80%)
	Battery operation time	6 h/200 exposures at 70 kV/20 mAs
	Standby time (On state)	12 h
	Standby time (Off state)	48 h
High power battery pack (90 Ah) ¹⁾	Battery	Sealed lead acid batteries (90 Ah), rechargeable
	Charging time	6.5 h (80%)
	Battery operation time	8 h/270 exposures at 70 kV/20 mAs
	Standby time (On state)	16 h
	Standby time (Off state)	64 h

Working environment

Environmental conditions

Operation

Temperature range	+ 10 °C to + 35 °C
Relative humidity	30% to 75%, non-condensing
Barometric pressure	800 hPa to 1060 hPa

Transport/storage

Temperature range	– 20 °C to + 60 °C
Relative humidity	10% to 75% (up to 15 weeks, if FD packed)
Barometric pressure	500 hPa to 1060 hPa

Dimensions and weight

Footprint (l x w x h)	127.8 cm x 59.8 cm x 157 cm (50.3" x 23.5" x 61.8")
Tube positioning:	
Max. focal spot height	213.5 cm (84")
Min. focal spot height	47 cm (18.5")
Max. horizontal ext.	124.5 cm (49")
Min. horizontal ext.	39.5 cm (14.4")
Weight (without optional accessories)	Approx. 380 kg

Room planning

Dimensions in cm (inches)

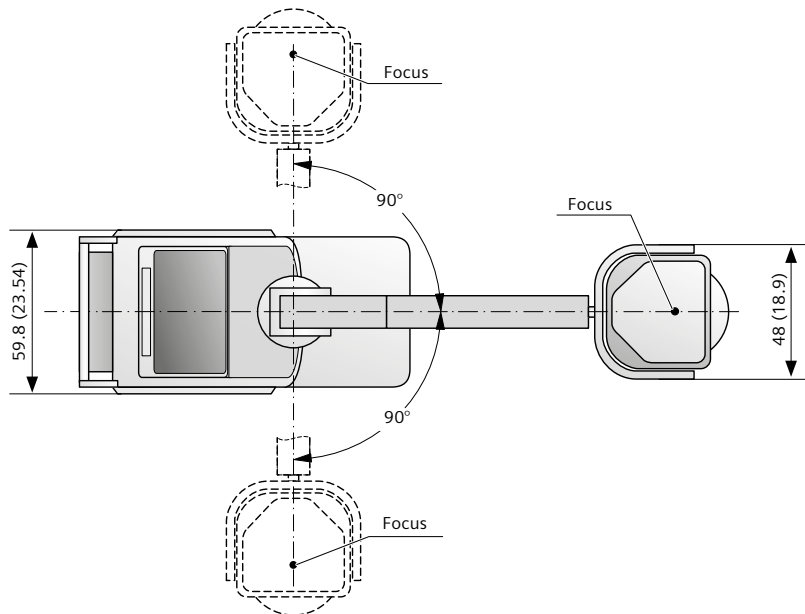
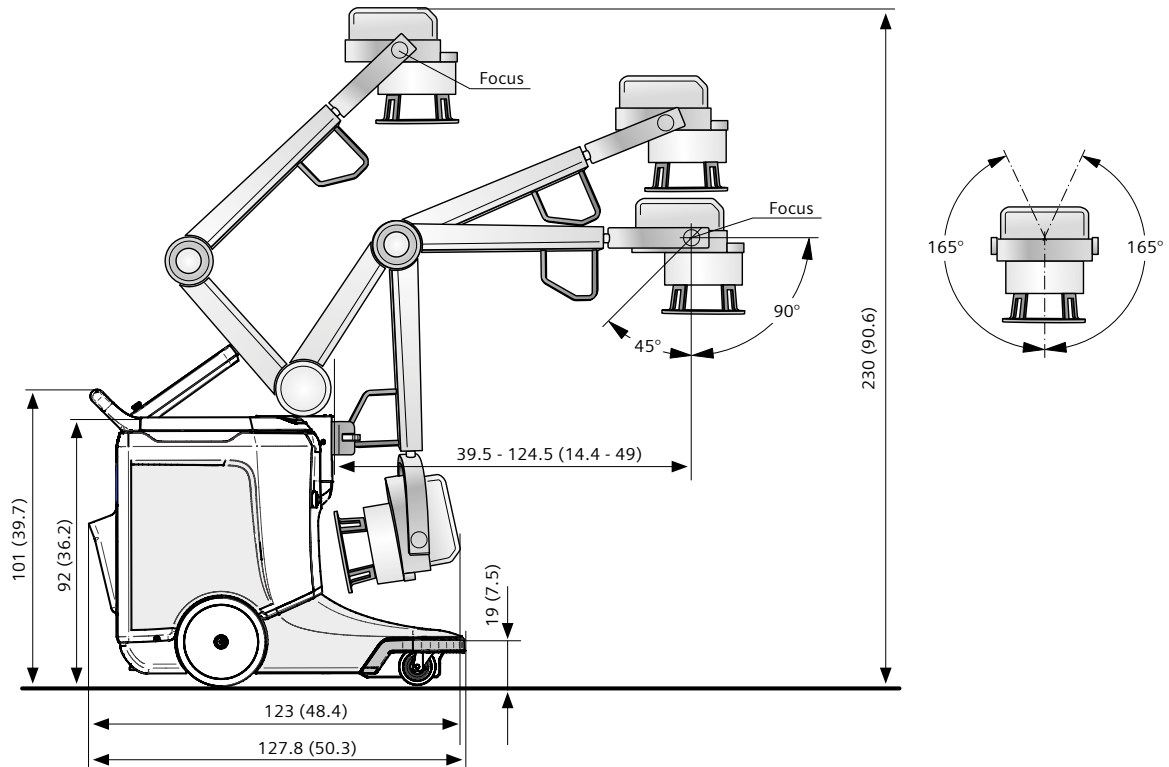

MOBILETT Elara Max VF10 is not yet available in all countries. Due to regulatory reasons, its future availability cannot be guaranteed. Please contact your local Siemens Healthineers organization for further details.

On account of certain regional limitations of sales rights and service availability, we cannot guarantee that all products/services/features included in this brochure are available through the Siemens Healthineers sales organization worldwide. Availability and packaging may vary by country and are subject to change without prior notice.

The information in this document contains general descriptions of the technical options available and may not always apply in individual cases.

Siemens Healthineers reserves the right to modify the design and specifications contained herein without prior notice. Please contact your local Siemens Healthineers sales representative for the most current information.

In the interest of complying with legal requirements concerning the environmental compatibility of our products (protection of natural resources and waste conservation), we may recycle certain components where legally permissible.

For recycled components we use the same extensive quality assurance measures as for factory-new components.

Any technical data contained in this document may vary within defined tolerances. Original images always lose a certain amount of detail when reproduced.

MOBILETT Elara Max
144 600 95
VF10

Siemens Healthineers Headquarters

Siemens Healthcare GmbH
Henkestr. 127
91052 Erlangen, Germany
Phone +49 9131 84-0
siemens-healthineers.com

Legal Manufacturer

Siemens Healthcare GmbH
Henkestr. 127
91052 Erlangen
Germany